

THIS DRAWING IS UNPUBLISHED. RELEASED FOR PUBLICATION, 19
 © COPYRIGHT 19 BY AMP INCORPORATED. ALL INTERNATIONAL RIGHTS RESERVED.

LOC	DIST	P	F	ZONE	LTR	DESCRIPTION	DATE	APPD
AF	50				B	RE-ACT & REL AF-5501	9/7/88	JR/RG

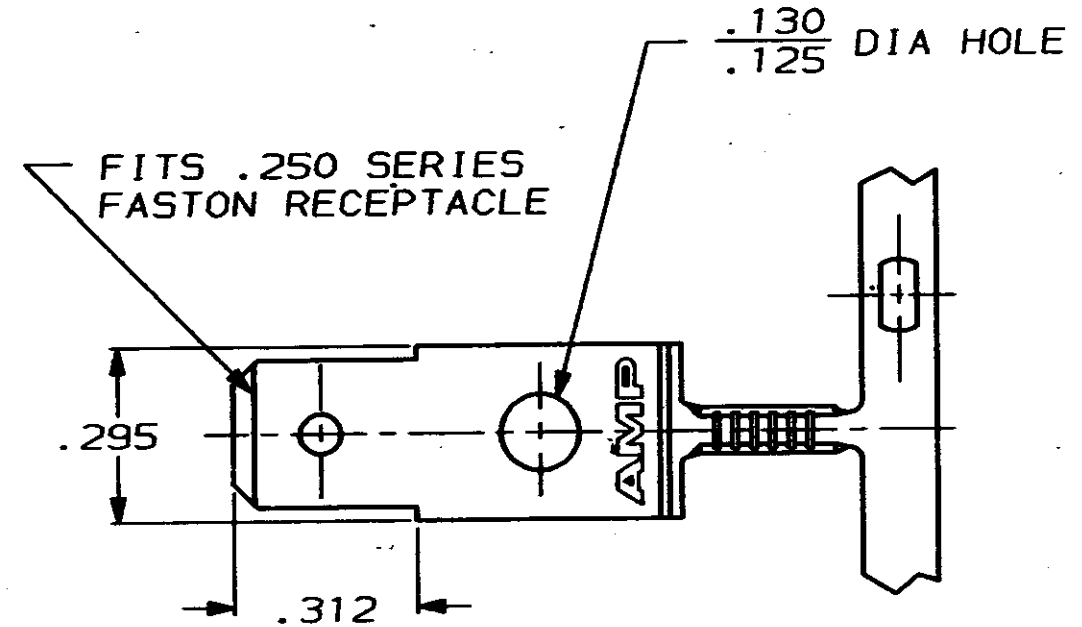

1 CONTINUOUS STRIP ON REELS.

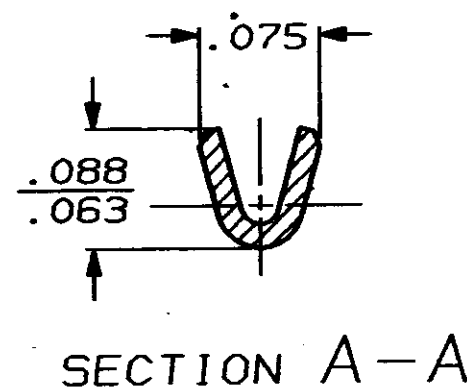
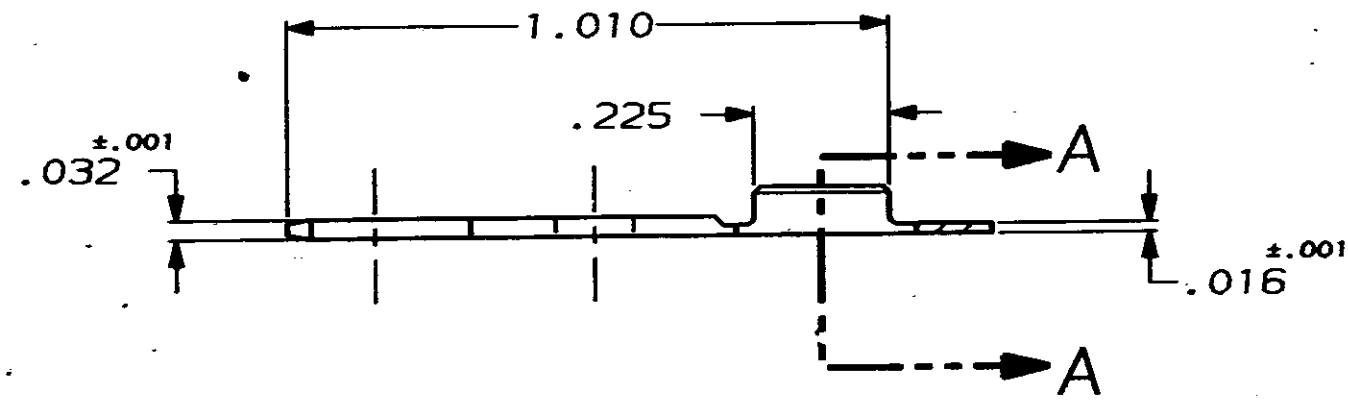

DO NOT SCALE PRINT. UNLESS SPECIFIED DIMENSIONS IN INCHES TOLERANCES ON: 2 PLC DEC ± - 3 PLC DEC ± .010 ANGLES ± -	DR JR RUTH 12/15/87 CHK M FEHER 12/16/87 APPO C MEYERS 12/21/87 APPO R KUZO 12/21/87
MATERIAL #2H BRASS PREMILLED	PRODUCT SPEC -
FINISH TIN VARNISH RESIST	APPLICATION SPEC -
	WEIGHT -

200-566 CMA	63483-1
WIRE SIZE	PART NO
AMP AMP INCORPORATED Harrisburg, Pa. 17105	
NAME TAB, FASTON, AMPLIVAR, .250 SERIES	
SIZE B	FSCN NO 00779
SCALE NTS	DRAWING NO 63483
	SHEET 1 OF 1