

SERPAC SE1530

Electronic Enclosures

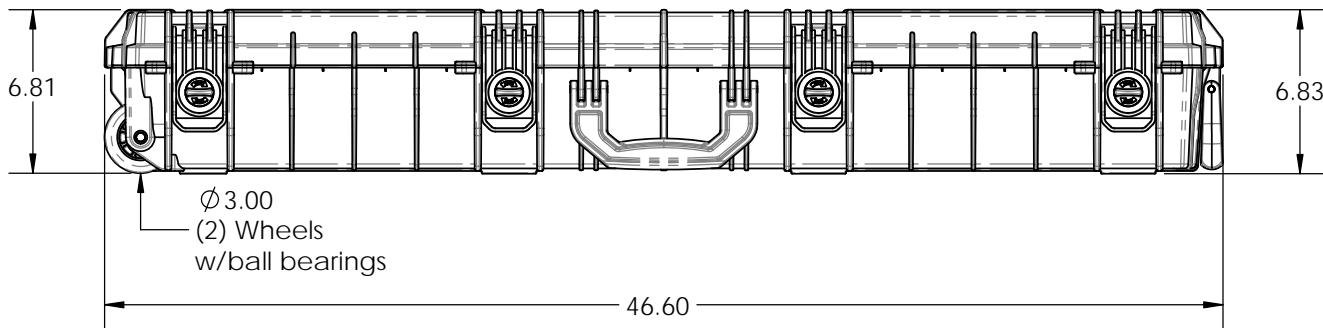

SE1530ML
Optional latch with metal lock. See note 4

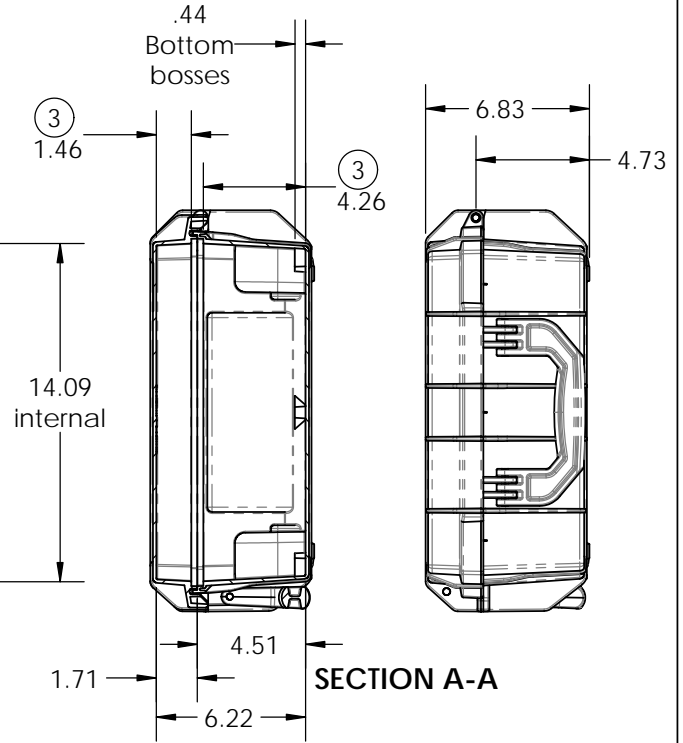
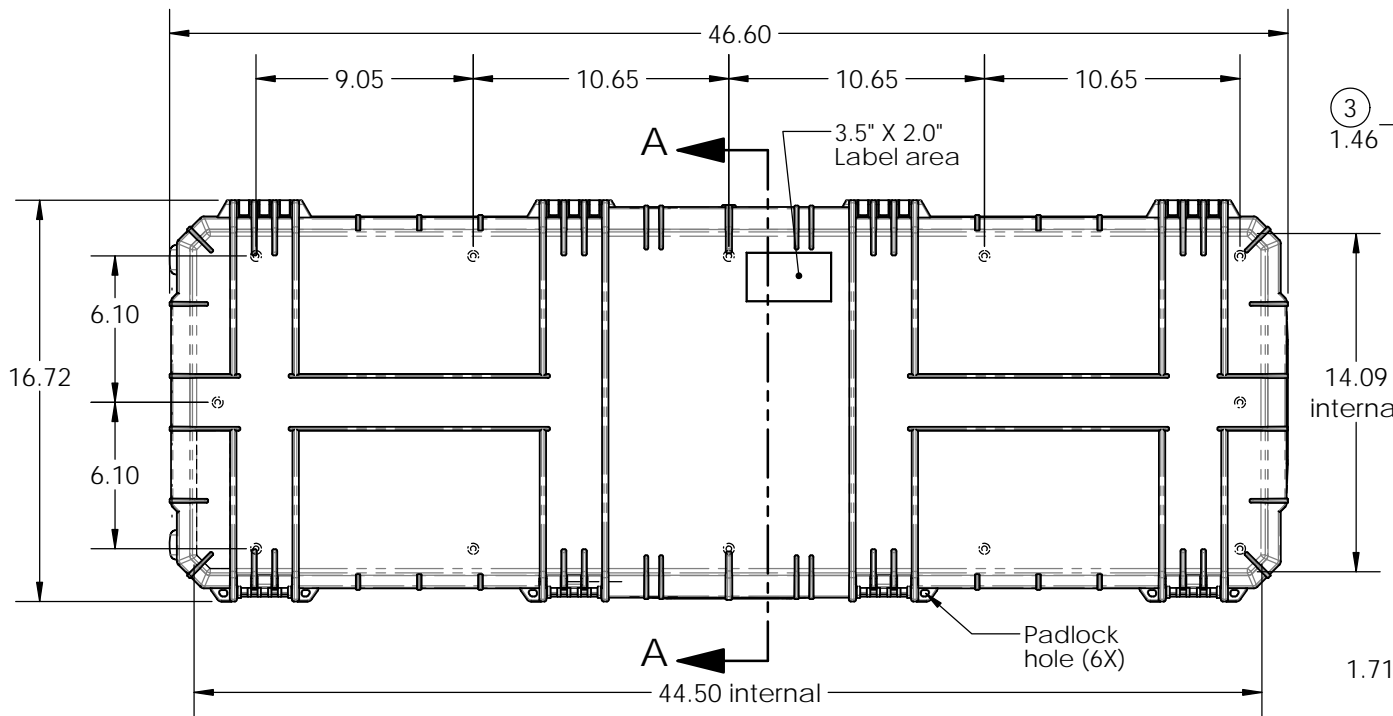
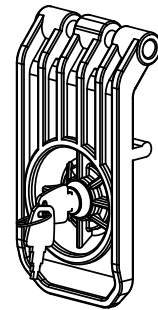

NOTES:

- 1) Max. usable inside dimensions are: 44.5" X 14.1" X 6.2" (5.7" top of boss) dim. are approx.
- 2) Bosses on bottom use a 1/4 self tapping screw.
- 3) Dimensions to bottom of panel flange.
- 4) Optional latches with Metal Lock Specify p/n SE1530ML.