

THIS DRAWING IS UNPUBLISHED. RELEASED FOR PUBLICATION
 © COPYRIGHT - By - ALL RIGHTS RESERVED.

LOC	DIST	REVISIONS			
P	LTR	DESCRIPTION	DATE	DWN	APVD
AF	50				
	B6	REVISED PER ECR-12-013219	08JAN13	KH	KR

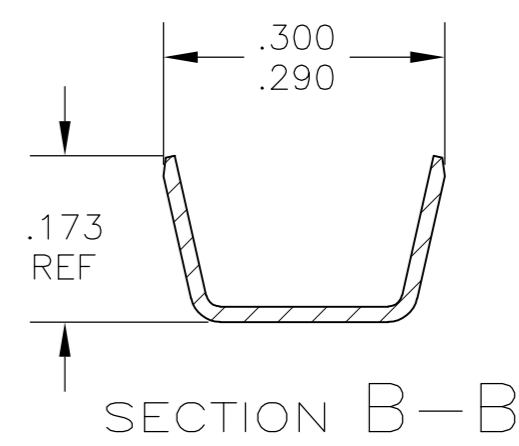
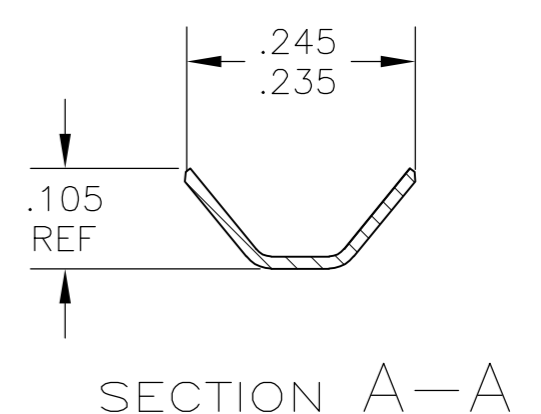
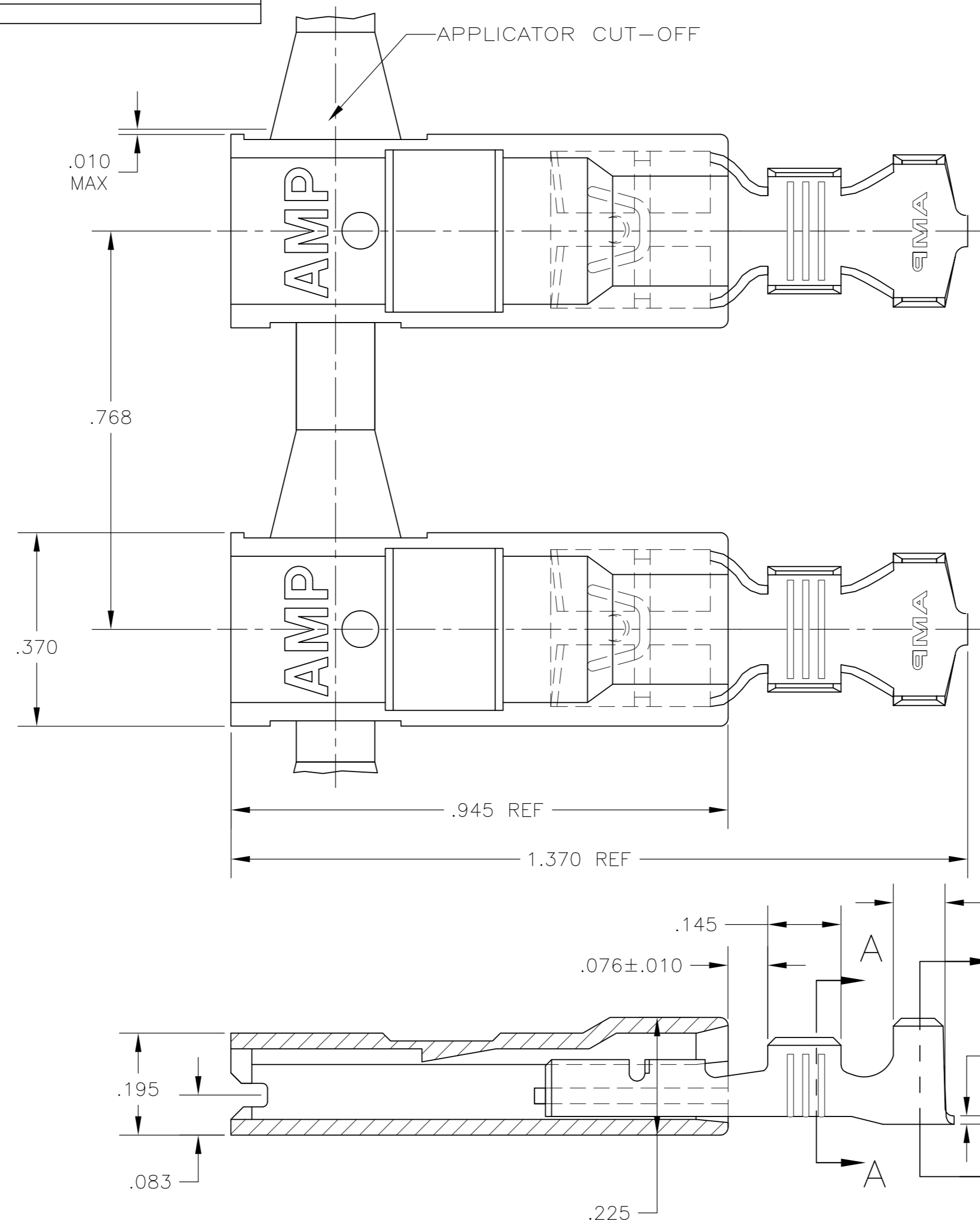

- 1 LOW-INSERTION FASTON TERMINALS ARE USED IN THIS PRODUCT.
- 2 TIN PLATE PER .000080 MIN
- 3 WIRE SIZE IS 18-14 OR TWO 18'S AWG OR TWO 20'S AWG
- 4 INSULATION RANGE IS .110-.170 DIA OR TWO .105 MAX DIA
- 5 MATING TAB THK IS .032±.001
- 6 PREPRODUCTION - F.A.S.R. REQUIRED.

STANDARD	6/6 NYLON, NATURAL	BRASS - TIN	2	521637-2
STANDARD	6/6 NYLON, NATURAL	BRASS - PLAIN	6	521637-1
PACKAGING	HOUSING MATERIAL & FINISH	TERMINAL MATERIAL & FINISH	PART NO.	

THIS DRAWING IS A CONTROLLED DOCUMENT.		DWN	JR RUTH	22MAY03	TE TE Connectivity
DIMENSIONS: INCHES		CHK	MS FEHER	22MAY03	
TOLERANCES UNLESS OTHERWISE SPECIFIED:		APVD	J HUMMEL	22MAY03	
0 PLC ± - 1 PLC ± - 2 PLC ± - 3 PLC ± .010 4 PLC ± - ANGLES ± - FINISH SEE TABLE		PRODUCT SPEC	108-1285		
MATERIAL SEE TABLE		APPLICATION SPEC	114-2124		NAME
		WEIGHT	-		ASSEMBLY, ULTRA-POD, RECEPTACLE, .250 SERIES
		CUSTOMER DRAWING	SIZE	A2	CAGE CODE
			00779	DRAWING NO	RESTRICTED TO
			SCALE	5:1	SHEET
				1 of 1	REV
					B6